

## Draft SPOTS Standard Part III (3)



CALIBRATION  
AND ASSESSMENT  
OF OPTICAL STRAIN  
MEASUREMENTS

---

---

**Good Practice Guide for Image Correlation for in-  
plane Displacement/Strain Analysis**

December 2005

## 1. Scope

The scope of this document is the measurement of a test specimen by image correlation methods for the purpose of extracting displacement measurements and subsequently strain measurements.

## 2. Reference materials

### ISO Norms

ISO 11145:2001 Optical instruments – Lasers and laser-related equipment – Vocabulary and symbols.

### ASTM Standards

E 2208-02 Standard Guide for Evaluating Non-Contacting Optical Strain Measurement Systems

## 3. Symbols and abbreviations

Symbol	Definition	Units
-	-	-

## 4. Terminology

<i>CCD</i>	Charge Coupled Device
<i>FFT</i>	Fast Fourier Transform
<i>DIC</i>	Digital Image Correlation
<i>Kohler illumination</i>	Kohler illumination provides very even specimen illumination for both visual and photo microscopy. It requires that the light source (lamp filament) be focused at the aperture diaphragm, the rear focal plane of the objective.
<i>Cross correlation</i>	A statistical measure describing the relative movements and proximity of alignment between two different sets of a series of positional information.
<i>AFM</i>	Atomic Force Microscope
<i>SEM</i>	Scanning Electron Microscopy

## 5. Principles of the method

Digital Image Correlation is a data analysis method which uses a mathematical correlation to analyse digital image data taken while samples are subjected to thermal or mechanical strain. Consecutive image captures taken during the testing phase will register a change in surface characteristics as the specimen is effected by the stresses imposed upon it.



Digital Image Correlation (DIC) relies upon the appearance of “fingerprint” digital grey-scale patterns locally over as much of the sample as possible. The technique compares two images acquired at different states, one before and one after some deformation. The two images may be referred to as a reference image (before the deformation) and a deformed image. After suitable acquisition by a CCD camera, digitised versions of both images are used for analysis.

Sub-images are chosen from both the reference and deformed images and are then compared. An initial estimate of the shift due to deformation is given which is usually accurate to 1 pixel. The nearest location is computed using the location of the most closely matched sub-image pattern or fingerprint which has the minimal value of mutual cross correlation. A fine search routine is then used to more accurately calculate the displacement to sub-pixel accuracies.

Figure 1 represents the image correlation process in its simplest form. An image of the specimen under test is taken in two different states of strain, in this case COLD and HOT. A small region of the image (called a sub-image) as observed in the cold state is selected and its match is then found in the hot image also. Using cross correlation algorithms, the size of the displacement between the two is then calculated to accuracies equal to small fractions of the size of each pixel of the CCD camera used to capture the images. One motion vector per sub-image is calculated. From the images, the analysis algorithm calculates the vector referencing the location of the sub-image (actually an array of  $N \times N$  pixels) in the deformed image to its location in the reference image. Thus an array of sub-image displacement vectors is calculated, showing the local relative displacement of different parts of the workpiece within the field of view of the optical system, under the thermal strain.

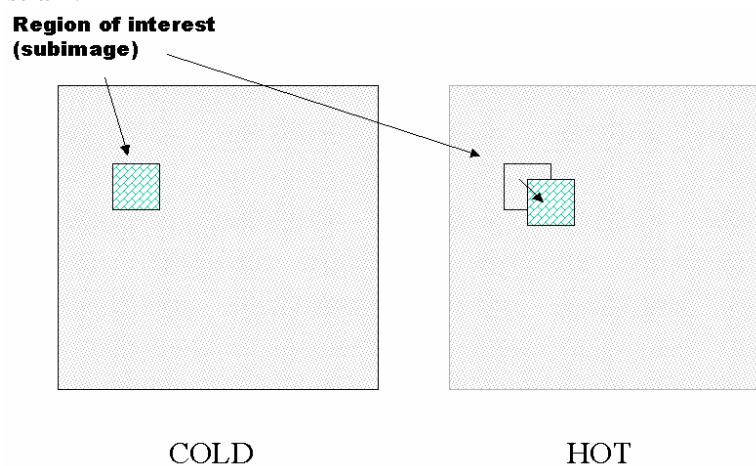

Figure 1. Basic principle of Digital Image Correlation: calculation of sub-image greyscale matrix motion deformation between two component images with different externally applied stresses.

The experimental set-up for DIC measurements may be quite varied as Optical, AFM or SEM apparatus may be used to acquire micrographs.

## 6. Apparatus

The basic apparatus for digital image correlation investigations consists of:

1. Digital CCD camera
2. Viewing/imaging optics
3. Lighting source
4. Stressing rig
5. PC with framegrabber

Below is a schematic of apparatus that may be used for image correlation measurements:-

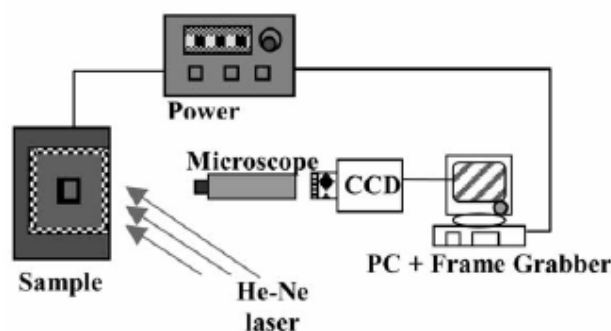

Figure 2 Simple schematic of a digital image correlation apparatus

In Figure 2, laser illumination is used to produce speckle. However, Figure 3 is a schematic of an apparatus utilising a white light source and standard Kohler illumination which may also be used:-

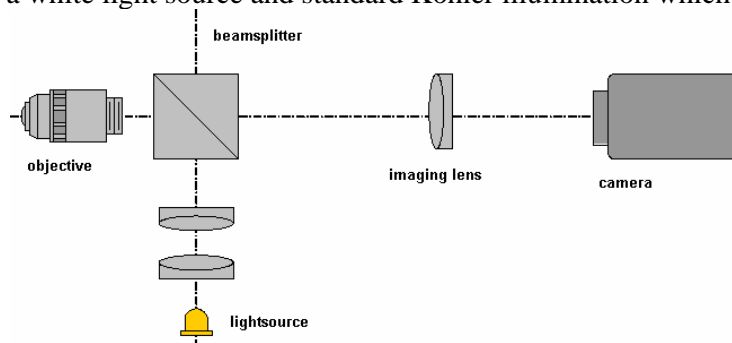

Figure 3. Kohler illumination

An imaging lens is used to produce an image of the specimen under test on a CCD camera. Illumination of the sample under investigation may be performed using a white light source or other means, so that a uniform illumination over the target area may be achieved.

In terms of stressing the sample under investigation, the apparatus depends on the type of stress required. In the case of thermo-mechanical stress investigations stressing may be achieved by placing the sample under investigation in a heating/cooling chamber with a viewing window.

In the case of purely mechanical testing investigations the sample may be placed in a tensile testing rig or tensometer.

## 7. Sample preparation

Image Correlation relies upon the appearance of local “fingerprint” digital greyscale patterns present within the analysis field of view.

The requirement for sample preparation depends on the magnification of the imaging system and the surface characteristics of the test specimen. But in general the technique requires sharp greyscale information of the order of 1 pixel in size at the CCD recording device.

In macro-deformation measurements a suitable surface may be obtained by first applying a randomised coating such as black paint or graphite.

At high magnifications colloidal graphite may still be used, or the material may be prepared so that it presents with local contrast. A simple polishing procedure for one such case is outlined below.

In any case the quality of the image correlation data should be checked by the use of a correlation coefficient, which is an output from the image correlation calculation and which gives a good indication of the success of the calculation based on the images used at stress state A and stress state B.

**In the case of 5X,10X,20X magnification (i.e. Micro Digital Image Correlation):**

Taking the wavelength of visible light as approximately 0.5 micron, samples having a roughness average of between 1 and 5 micron may be expected to produce a highly micro-textured image, which will facilitate the measurement of deformation. Such slightly non-specular surfaces are the ideal for Micro-Image Correlation analysis. Excessive roughening can also impair the image quality.

To obtain the best results with Image Correlation, the surface of the sample which is to be inspected must have a matt finish microtexture. Otherwise it needs to be micro-roughened, so that a small sub-image area within the field of view has a lot of different grey scales in the digital image.

*Sample Surface Texture Preparation*

The best approach to sample preparation can be summarised by the expression “macro-polish (i.e. make them flat) but micro-roughen (i.e. make them matt rather than shiny)”.

With cross-sectioning, a common sample preparation will consist of polishing cross-sectioned samples with progressively finer abrasives down typically to a 1 micron or finer grit. In this case, it is recommended that this be followed by a controlled micro-texturing of the cross-section surface using typically a slightly coarser abrasive, to micro-texture the sample.

The use of similar ranges of wet waterproof sandpaper is also found to work, and is preferably carried out using machine polishing and texturing.

The surface microtexture should be optimised for the objective lens which it is proposed to use in the study.

Objective lens magnification	Grit nominal size for machine polish/texture	Wet abrasive paper grade for machine polish/texture
X2	3-6 micron	P1200
X5	3-6 micron	P1200
X10	1-3 micron	P2500
X20	0.5 - 1 micron	P4000

In the absence of the preferred polishing machinery, manual texturing may be performed using wet waterproof sandpaper, taking care to sand the sample in random directions. Ultimately, the sample must be optically inspected to see that it has a matt finish.

## 8. Calibration procedure

Calibration for image correlation techniques requires a direct technique for calculating the magnification of the imaging system.

This is a factor to convert the image at the CCD plane (in pixels) into the object (in metres).

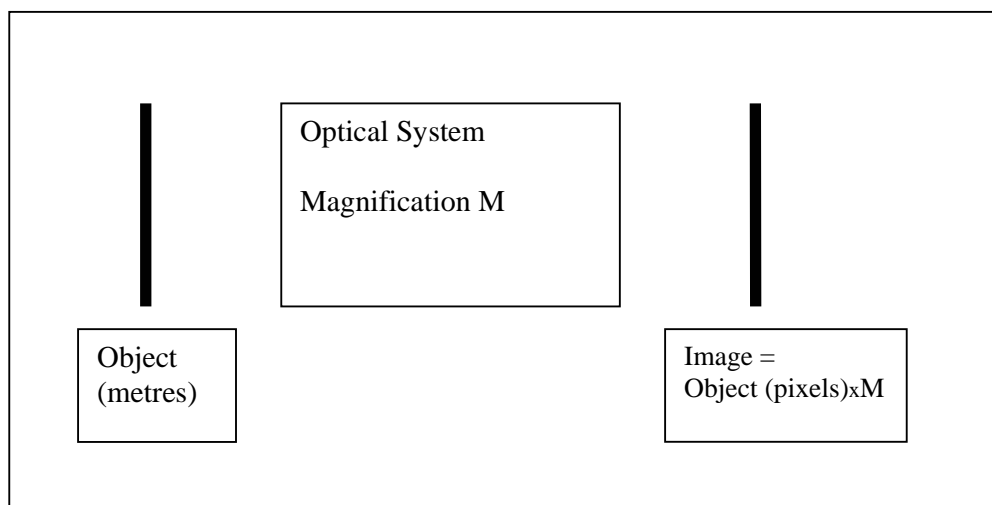

Figure 4. Set-up for calibration of magnification.

This may be achieved by the use of a traceable calibration standard such as a calibrated micrometre gauge. Imaging of this gauge at the object plane onto the CCD plane will allow a calibration of the imaging system, as indicated in Fig.4.

## 9. Recording and measurement procedures

The recording procedure for image correlation consists of the following steps and is illustrated in Fig.5:

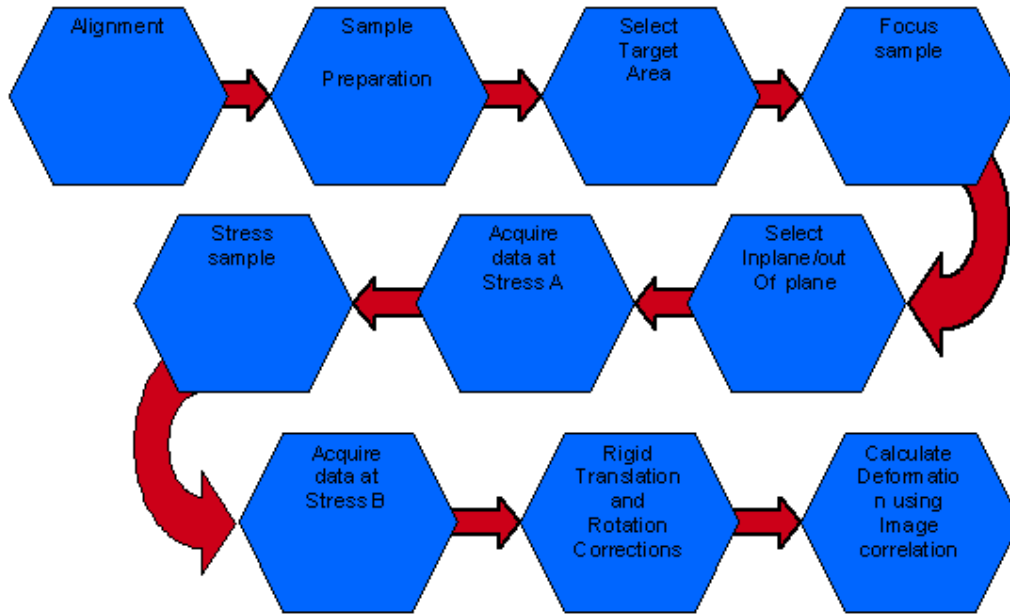

Figure5. Recording and measurement procedures

1. Alignment of the optical system. The optical system used to gather the images at each state must be set up correctly in order to avoid image aberration and to ensure that the sample illumination is as uniform as possible across the field of view of the CCD camera.
2. Sample preparation. The extent of sample preparation depends on the optical magnification used. The sample must be prepared so that the image correlation algorithm performs effectively, i.e. the correlation coefficient (the measure of good correlation) must be in the acceptable zone.
3. The target area on the sample must be selected using the imaging system.
4. The sample should then be focused. This focus should be repeated whenever the target area moves out of the focus range during a measurement.
5. The mode of measurement must be selected. This may be in-plane or out-of-plane depending on the system.
6. An in-focus image of the target area should be acquired at the initial state of the target area (Stress State A).
7. The sample under investigation should be stressed, using heat or other means.
8. An in-focus image of the target area should be acquired at the second state of the target area (Stress State B).
9. Rigid motions should be corrected for. These include rigid linear translation and rigid rotation of the sample under investigation.
10. The deformation may then be calculated using the data processing procedure.

## 10. Data processing procedures

Principle of digital image correlation for the measurement of sample displacement:

- 1) Sequence of events during a correlation measurement:

- Record one image before deformation.
- Apply deformation-inducing agent
- Record a second image after deformation
- Cross-correlate the two images to generate a correlation map
- Extract the displacement from the correlation
- Validate the deformation measurement
- Extract information on strain, - direct and shear.

2) Recording high resolution data images. High resolution correlation calculations require high resolution images to achieve maximum accuracy. The sample is placed in the best focal plane to ensure that the best focus is achieved. For large fields of view, it can be difficult to achieve optimum focus over the full field. This is also true when a sample is not perfectly flat. Three factors can affect the non-planarity of the sample : the first one is when the sample itself is non-planar. The second one is a non flat positioning in the sample holder. Finally, the third reason comes from deformation in the Z axis when the sample is subject to changes of temperature or stress. To palliate these effects, multiple images are acquired above and below the median focal plane, at a spacing equivalent to the focus function resolution. The field of view can then be broken into areas, each of which is selected from the image displaying the highest resolution at that location.

3) Rigid-body motion calculation. The high resolution of the imaging process, as well as the potentially large movement of the sample during deformation, mean that the field of view, as a whole, must be shifted to cover the same area of the sample. This is done to a resolution of  $\pm 0.5$  pixels. This prevents non-overlapping areas in the pre- and post-deformation images.

4) Local displacement calculation. The displacement map is established by dividing the pre- and post-deformation images into registered sub-images of known size. As most correlation calculations are carried out in reciprocal space using Fast Fourier Transform algorithms, their size is always a power of two, i.e. 16 pixels square, 32 pixels square, 64 pixels square, etc. A displacement vector is calculated for each sub-image, using the correlation algorithm. The vector represents the average movement of the sub-image from its original position before deformation to its new position after deformation. The smaller the sub-image size, the better the lateral resolution associated with the displacement vector. However, there is a trade-off between displacement resolution calculation and lateral resolution. The highest displacement vector resolution is achieved with an area presenting a high resolution texture, moving as a rigid body. Large sub-images can then be used, giving rise to very high resolution displacement vectors. At interfaces, smaller sub-images have to be used. The displacement resolution decreases for small sub-images, but the accuracy of the vectors remains higher than those computed from large sub-images due to the gain in spatial resolution.

5) High resolution correlation calculation. A number of techniques are used to improve the accuracy of the correlation and reach a sub-pixel displacement resolution.

- One approach to Digital Image Correlation (DIC) is to use a combination of curve fitting to the correlation peak and non-integral pixel shifting of sub-images.
- Alternatively, high accuracy may be achieved without fitting an analytical expression to the correlation peak by using successive approximation non-integral pixel shifting. Aligning the sub-images to sub-pixel accuracy prior to calculating the correlation coefficient is necessary to achieve high precision. Non-integral pixel shifting may be used to iteratively search for the correlation peak. The algorithm proceeds by first aligning the sub-images to within 0.5 pixels. The second sub-



image is then sub-pixel shifted and re-correlated with the first sub-image. Sub-pixel shifting entails multiplying the spectrum of the sub-image by a linear phase gradient before re-correlating. The results of successive correlations are used to make better estimates of the true peak position in a manner analogous to successive approximation analog-to-digital conversion. Iteration continues until the required accuracy has been achieved or the algorithm converges, indicating a noise limited result.

6) Validation of displacement measurement. Each correlation calculation of sub-images provides three results : a vector defined by its X and Y coordinates and a correlation coefficient. The higher the correlation coefficient, the more accurate the result. However, some aberrations can occur (such as the correlation of perfectly featureless sub-images), returning correlation coefficients of maximum value. Therefore, some extra metrics are used to assess the correlation validity. These are statistical analysis and resolution assessment of the sub-images.

7) Derivation of deformation data to produce strain and shear maps. Deformation maps, composed of all individual sub-image displacements, can be used to produce strain maps. Strain maps are derivatives which are computed discretely ( difference map) with or without smoothing and filtering functions such as spline smoothing or interpolation. Derivatives are computed along one axis, which is historically the X or Y axis of the image. However, some algorithms compute the resultant of all strains applied to one point, giving both the local amplitude and direction of the principal strain.

## 11. Areas of applications

In plane image correlation may be used in the following fields:

Thermo-mechanical analysis of deformation and strain in microelectronics, microsystems, micro optics

Strain characterisation in automotive and aeronautical applications

Deformation and strain analysis of medical devices such as cardiovascular stents

Nano-deformation analysis of materials using Scanning Electron Microscopy and AFM

## 12. Bibliography

1. M. Sjudahl and L. R. Benckert, "Electronic speckle photography: analysis of an algorithm giving the displacement with subpixel accuracy," *Applied Optics*, 32, (13), 2278-2284, 1993.
2. M. Pitter, CW See, JL Goh and MG Somekh, "Focus errors and their correction in microscopic deformation analysis using correlation", *Optics Express*, 10, (23), 1361-1367, 2002.
3. M.Pitter,CW See and MG Somekh, "Subpixel microscopic deformation analysis using correlation and artificial neural networks", *Optics Express*, Vol. 8, (6), 322-327, 2001.
4. M. Sjudahl and L. R. Benckert, "Systematic and random errors in electronic speckle photography", *Applied Optics*, 33, (31), 7461-7471, 1994.
5. M. Sjudahl, "Electronic speckle photography: increased accuracy by non-integral pixel shifting", *Applied Optics*, 33, (28), 6667-6673, 1994.
6. J Abanto-Bueno, J Lambros, "Investigation of crack growth in functionally graded materials using digital image correlation", *Engineering Fracture Mechanics*, 69, (14-16), 1695-1711, 2002.

7. Y Wang and AM Cuitino, "Full-field measurements of heterogeneous deformation patterns on polymeric foams using digital image correlation", *Int Journal of Solids and Structures*, 39, (13-14), 3777-3796, 2002.
8. RD Pendse and P Zhou, "Methodology for predicting solder joint reliability in semiconductor packages", *Microelectronics Reliability*, 42, (2), 301-305, 2002.
9. D Vogel, A Gollhardt and B Michel, "Micro- and nano-materials characterization by image correlation methods", *Sensors and Actuators A-Phys*, 99, (1-2), 165-171, 2002.
10. M. Sjudahl, "Accuracy in electronic speckle photography", *Applied Optics*, 36, (13), 2875 – 2885, 1997.

